

**NEW**

# RTK® REACT EQ-L

## ELECTRIC INTELLIGENT LINEAR ACTUATORS FOR HIGH-RANGE FORCE OUTPUT UP TO 30KN/6750LBF

When process operations depend on 100% running time, control valve actuators must offer unrivaled performance together with low maintenance requirements. When opening/closing forces from 15 kN/3380 lbf up to 30 kN/6750 lbf are also needed, the RTK REact EQ-L electric actuator has it all in one intelligent package. RTK REact EQ-L offers system-protecting functions for medium-to-heavy applications with higher pressure drops or large or unbalanced valve trims.



**Sea  
air-resistant  
variant**



**Protection Ratings  
& Certifications**

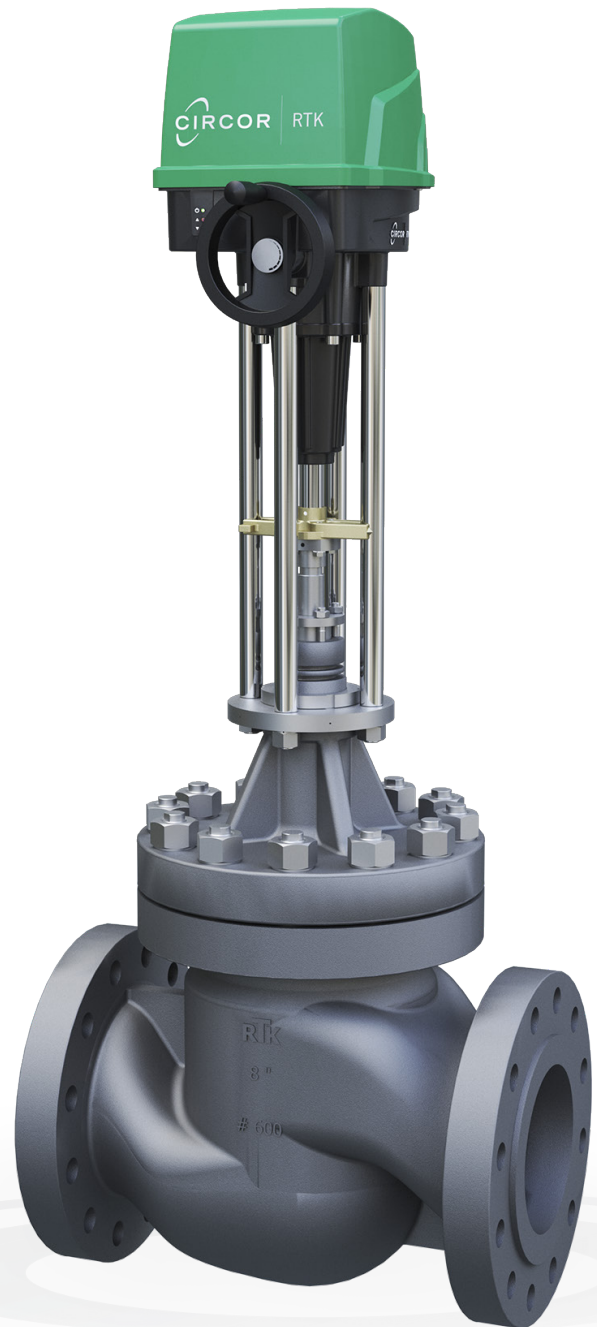

## BLDC MOTOR TECHNOLOGY – READY FOR WHAT'S NEXT

Replacement of old-school synchronous drive technology has never been easier for industrial, chemical, power and process actuation requirements.

### REact EQ-L:

- › Uses the newest brushless DC (BLDC) motor system, offering high force in a lightweight, compact size and delivering up to 60% energy savings compared to synchronous drives.
- › Is programmed with over force limiting technology to protect the valve and actuator, allowing the motor to self-regulate and serve as a built-in safety feature.
- › Is a smart controller with different preset speeds that can easily be selected.
- › Opens the door for Industry 4.0 functionality and flexibility for multiple signal exchange systems in open digital protocols for process automation, including Profibus and CANopen.
- › Unlike other electric actuators, works to help ensure 100% running time (24/7).

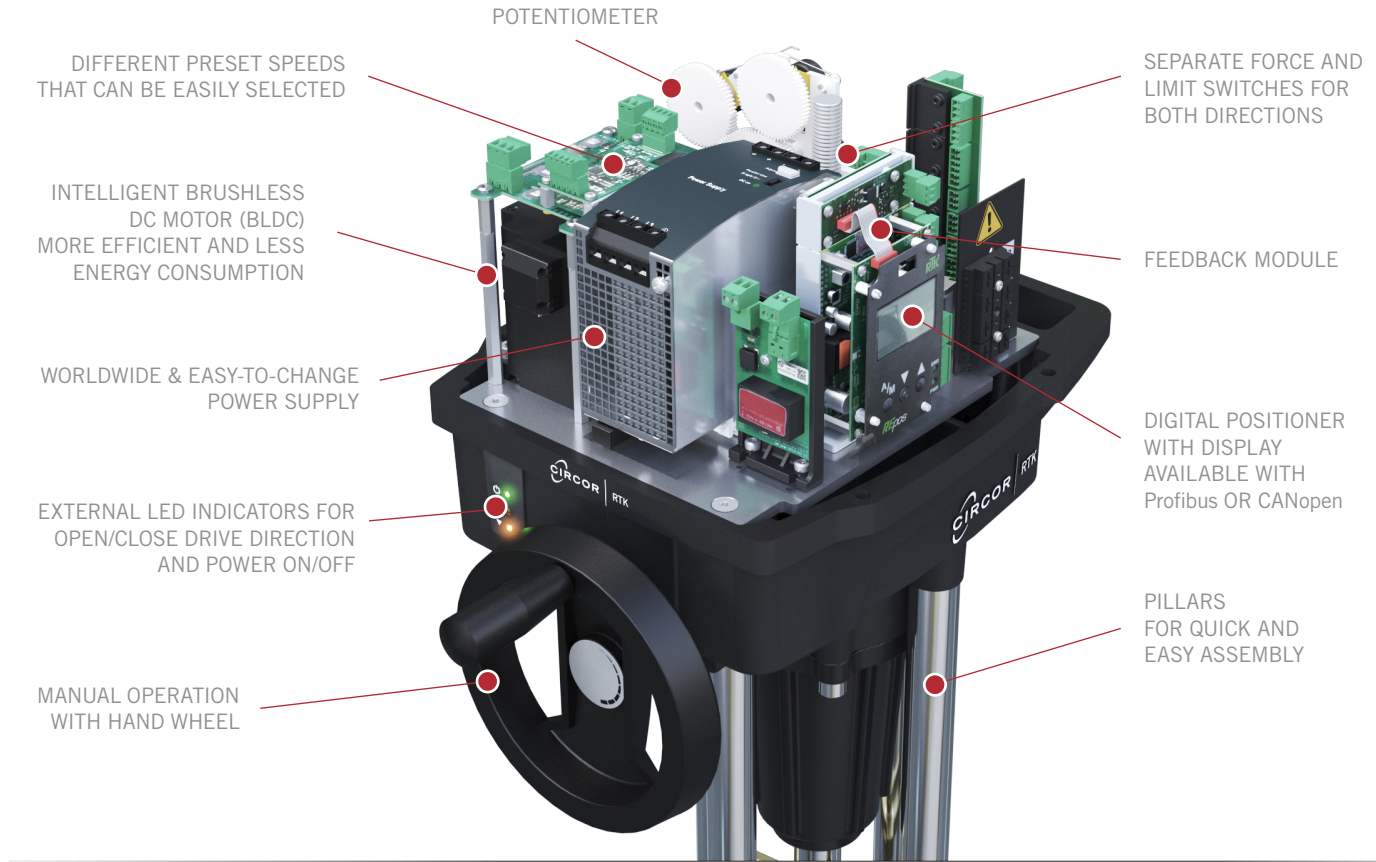

## WORLDWIDE OPERATIONAL FLEXIBILITY

Approved for protection rating IP 66 and NEMA 4x, and NRTL certification, REact EQ-L's single gear unit-motor combination offers three different open/close force outputs: 15 kN (3380 lbf), 22kN (4950 lbf) and 30 kN (6750 lbf). The actuator works in power ranges 100V(AC) to 240V(AC) or 380V(AC) to 480V(AC), allowing it to cover all regions, and offers plug stroke distances up to 100mm/4in. Simple modifications are all that is needed when system requirements change or need to be better optimized. A sea air-resistant variant for onshore applications is also available.

## AT-A-GLANCE SYSTEM STATUS TO SUPPORT ASSET MANAGEMENT

While digital BLDC technology works to help assure 100% running time, REact EQ-L's external LED clearly displays operating directions and power status for easy monitoring. Outfitted with RTK's optimized REpos digital positioner, this actuator offers data logging functions and the possibility for remote control through Profibus or CANopen. Using field device notification of diagnostic status, users can expect to conduct timely, status-based intervention to promote higher system availability and reduced maintenance costs.

## SAY GOODBYE TO COSTLY SURPRISES

When force outputs are high, keep damages to valve parts and actuators low with RTK's REact EQ-L. It's an innovative system-protecting solution that combines RTK's signature modular design with more efficient, adaptable and connected actuator technology.

Learn more and contact us at:  
<https://www.circor.com/rtk/contact>

